

General information

Cavity

Type series: C0820

Dimensions and sectional view

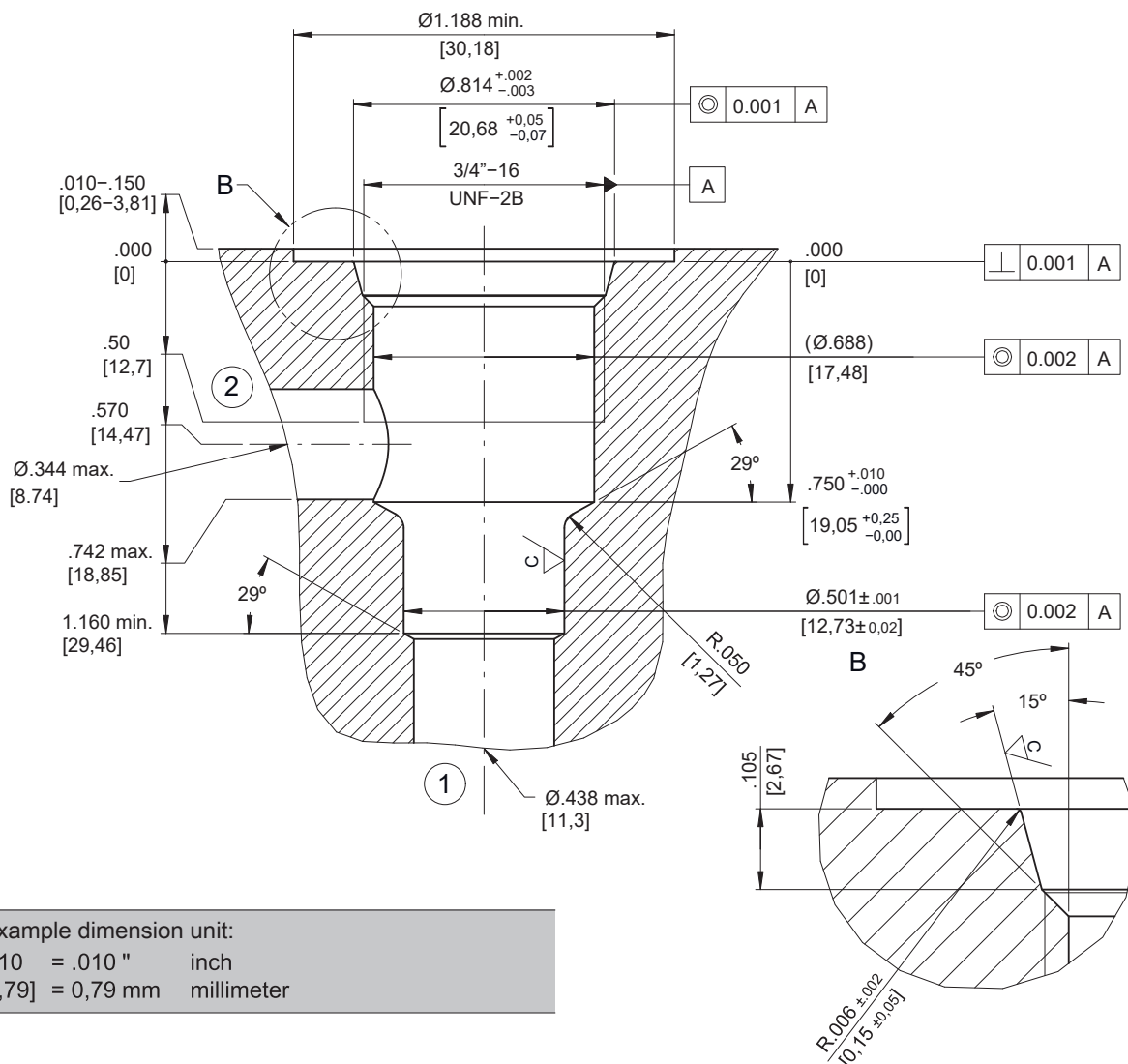

Example dimension unit:

.010 = .010 " inch
[0,79] = 0,79 mm millimeter

Dimension Tolerances	
Unless otherwise specified	
0.000	± .005"
0.00	± .010"
Angles	± 1/2°

Surface roughness		
	C	D
Ra	45 µin	125 µin
	(1.15 µm)	(3.2 µm)
	D Unless otherwise specified	

Installation information

**ATTENTION!**

You must maintain the specified positional and diametral tolerances. To ensure trouble-free operation of the screw-in cartridges, we strongly recommend that pilot drilling, boring, reaming and cavity thread-cutting are always performed in one setup.

**NOTE!**

Cavity type to factory standard.

**NOTE!**

We offer form tool sets for sale or hire. See data sheet 520-P-000050 for further information.